

TOPKIT MD 175

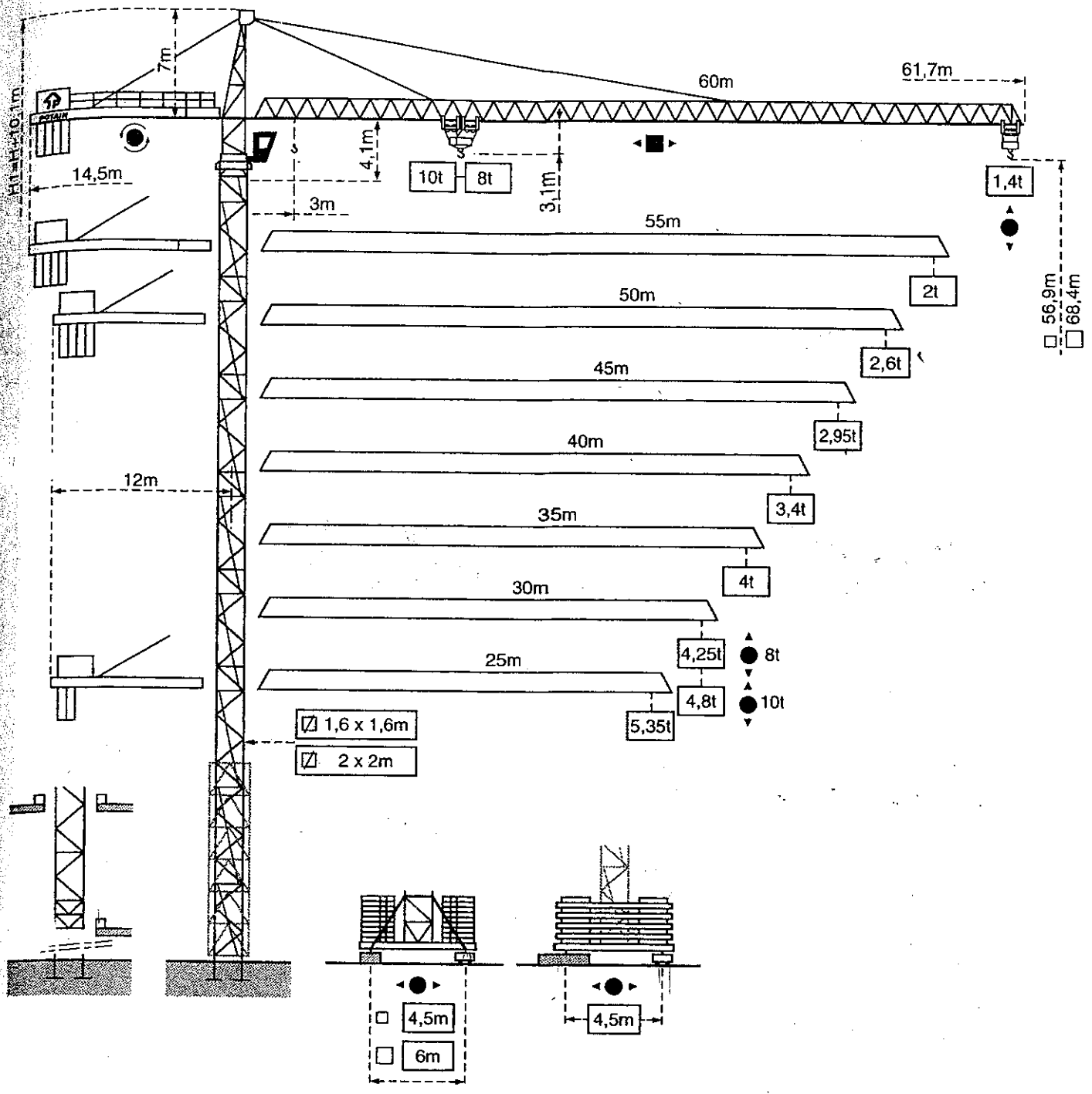

TOPKIT MD 175

POTAIN

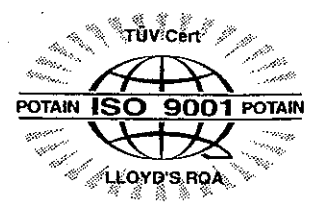

Mats - Maste - Masts - Mástil - Torre

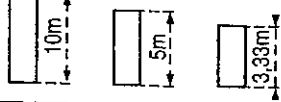

□ 1,6m
MD 175 G8 - MD 175 G10

Flèche - Ausleger - Jib
Flecha - Braccio
25m → 55m

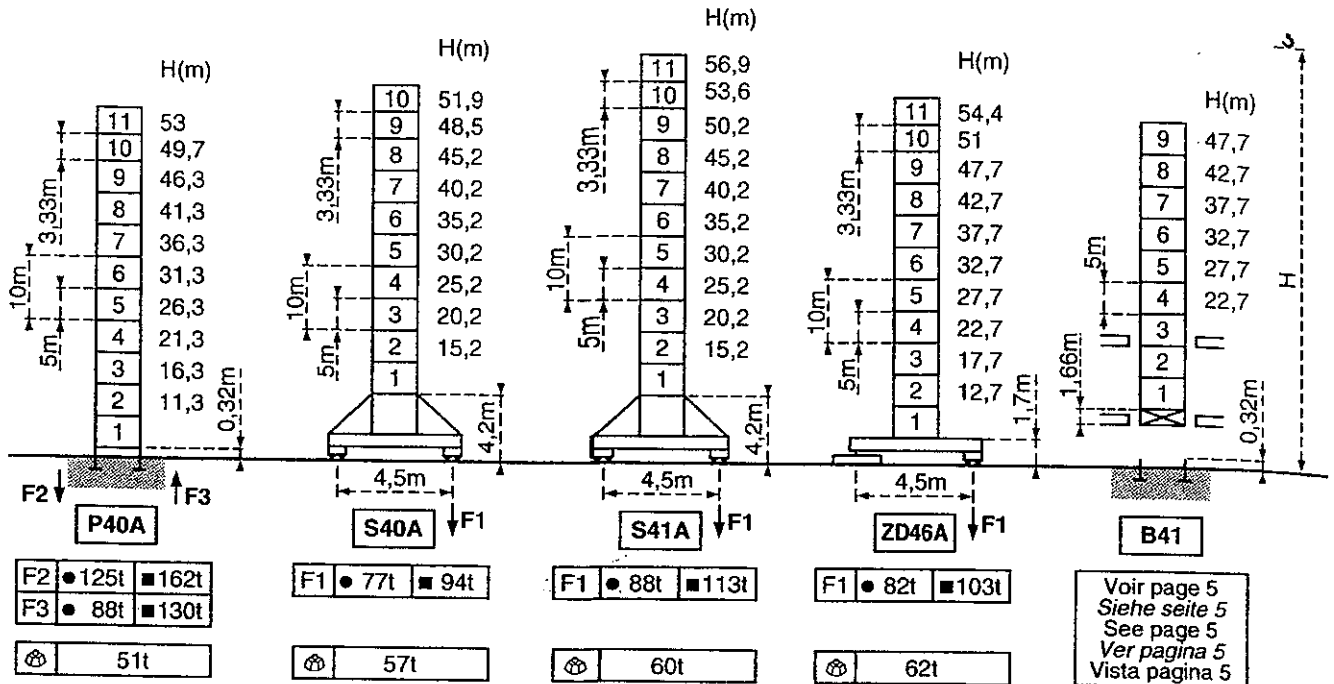

Mats - Maste - Masts - Mástil - Torre

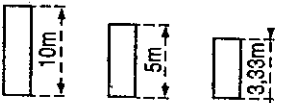

□ 2 m
MD 175 H8 - MD 175 H10

Flèche - Ausleger - Jib
Flecha - Braccio
25m → 60m

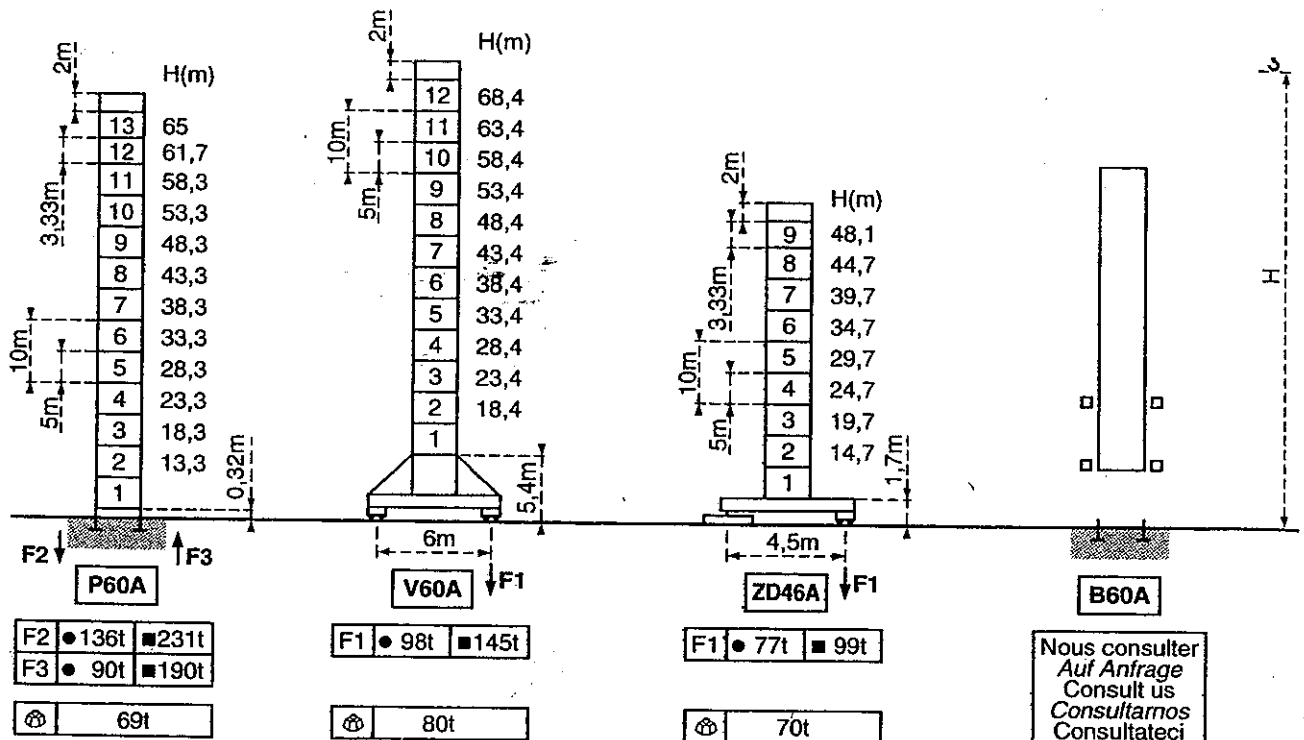

F = Réactions - Eckdrücke - Reactions - Reacciones - Reazioni

Flèche
Ausleger
Jib
Flecha
Braccio

Courbes de charges - Lastkurven - Load diagrams - Curvas de cargas - Curve di carico

MD 175 H8 - MD 175 G8

	13,6	15	17	20	22	23,6	26,3	30	32	35	37	40	42	45	47	50	52	55	57	60	m
60m	8	7,1	6,1	5	4,4	4	4	3,4	3,2	2,84	2,66	2,41	2,26	2,07	1,96	1,8	1,71	1,58	1,51	1,4	t
	16	17	20	22	25	28,1	31,3	32	35	37	40	42	45	47	50	52	55				m
55m	8	7,5	6,1	5,5	4,6	4	4	3,9	3,5	3,3	2,98	2,81	2,58	2,45	2,26	2,15	2				t
	17,8	20	22	25	27	30	31,3	34,9	37	40	42	45	47	50							m
50m	8	7	6,2	5,3	4,8	4,2	4	4	3,7	3,4	3,2	2,96	2,81	2,6							t
	17,8	20	22	25	27	30	31,3	34,9	37	40	42	45									m
45m	8	7	6,2	5,3	4,8	4,2	4	4	3,7	3,4	3,2	2,95									t
	17,8	20	22	25	27	30	31,3	34,9	37	40											m
40m	8	7	6,2	5,3	4,8	4,2	4	4	3,7	3,4											t
	17,9	20	22	25	27	30	31,4	35													m
35m	8	7	6,3	5,35	4,9	4,2	4	4													t
30m	8	7	6,3	5,35	4,9	4,25															t
25m	8	7,1	6,3	5,35																	t

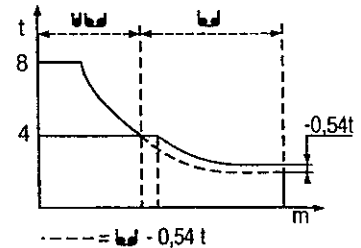

MD 175 H10 - MD 175 G10

	11,2	15	17	19,9	21,7	25	27	30	32	35	37	40	42	45	47	50	52	55	57	60	m
60m	10	7,1	6,1	5	5	4,3	3,9	3,4	3,2	2,84	2,66	2,41	2,26	2,07	1,96	1,8	1,71	1,58	1,51	1,4	t
	13,3	15	17	20	22	23,5	25,8	30	32	35	37	40	42	45	47	50	52	55			m
55m	10	8,7	7,5	6,1	5,5	5	5	4,2	3,9	3,5	3,3	2,99	2,81	2,58	2,45	2,26	2,15	2			t
	14,7	15	17	20	22	25	26,3	28,7	32	35	37	40	42	45	47	50					m
50m	10	9,8	8,5	7	6,2	5,3	5	5	4,4	4	3,7	3,4	3,2	2,96	2,81	2,6					t
	14,7	15	17	20	22	25	26,3	28,7	32	35	37	40	42	45							m
45m	10	9,8	8,5	7	6,2	5,3	5	5	4,4	4	3,7	3,4	3,2	2,95							t
	14,7	15	17	20	22	25	26,3	28,7	32	35	37	40									m
40m	10	9,8	8,5	7	6,2	5,3	5	5	4,4	4	3,7	3,4									t
	14,9	15	17	20	22	25	26,3	28,8	30	32	35										m
35m	10	9,8	8,5	7	6,3	5,4	5	5	4,8	4,4	4										t
30m	10	9,9	8,5	7	6,3	5,4	5	5	4,8												t
25m	10	8,6	7,1	6,3	5,35																t

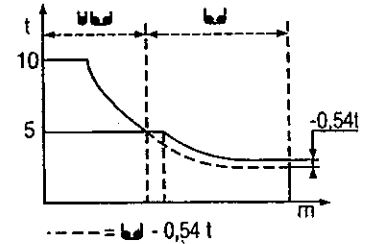

Ancrages - Verankerungen - Anchorages - Anclaje - Ancoraggio

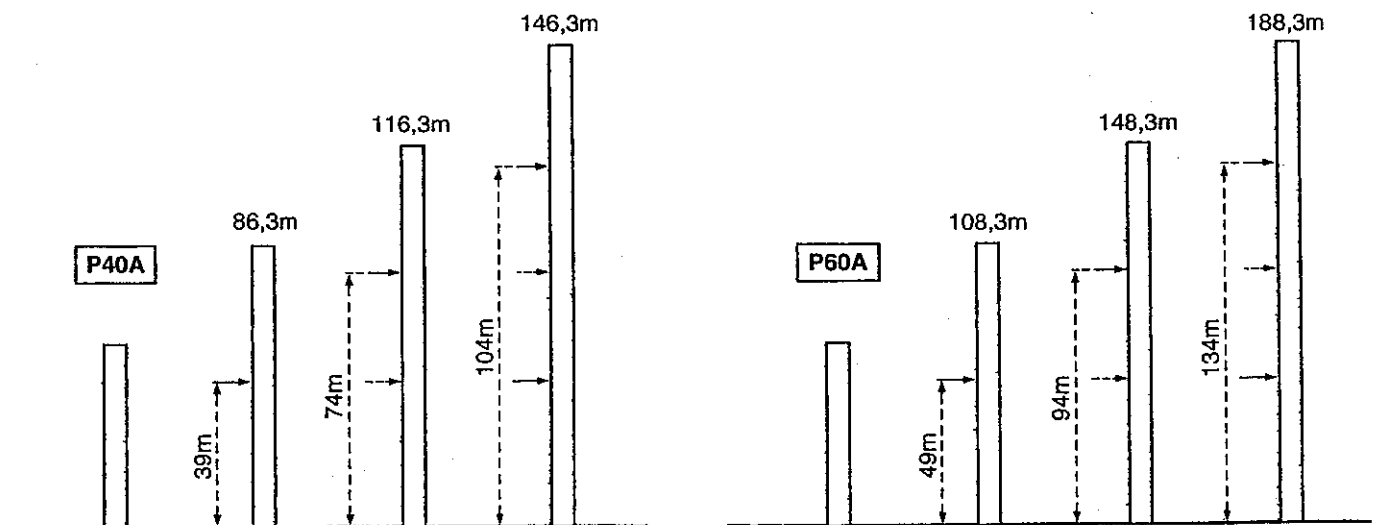

● En service
■ Hors service

● In Betrieb
■ Ausser Betrieb

● In service
■ Out of service

● En servicio
■ Fuera de servicio

● In servizio
■ Fuori servizio

⊗ A vide sans lest
avec flèche et hauteur
maximum.

⊗ Ohne Last und Ballast
mit Maximalausleger und
Maximalhöhe.











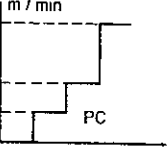

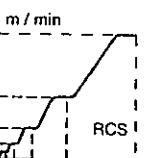

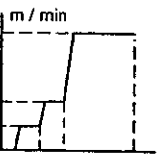

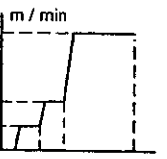
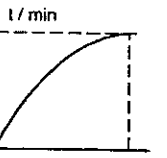
⊗ Without load and
ballast with longest jib
and maximum height.

⊗ Sin carga, sin
lastre con flecha y
altura máxima.

⊗ A vuoto senza zavorra
e con braccio massimo e
altezza massima.

POTAIN TOPKIT MD 175

Mécanismes - Antriebe - Mechanisms - Mecanismos - Meccanismi



			m/min	t	m/min	t		ch -PS hp	kW	
Levage Heben Hoisting Elevación Sollevamento		 8t	33	5,4	4	2,7	8	349m >349m*	33	24
			PC	30	4	15	8			
			20D	60	2	30	4			
		 10t	55	0⇒52	4	0⇒26	8	566m >566m*	55	40,5
			RCS	0⇒104	2	0⇒52	4			
			20D							
			33	4,3	5	2,2	10		33	24
			PC	24	5	12	10			
			25D	48	2,5	24	5			
			55	0⇒42	5	0⇒21	10			
			RCS	0⇒84	2,5	0⇒42	5	560m	55	40,5
			25D					>560m*		
Distribution Katzfahren Trolleying Distribución Diritubuzione			5 D3 V4			15-30-58		5	3,7	
Orientation Schwenken Slewing Orientación Rotazione			RCV 145			0⇒0,8 tr/min rpm		2x6	2x4,4	
Translation Kranfahren Travelling Traslación Traslazione			RT 324			12,5 -25		2x7	2x5,2	
			TCV 449 ARC H ≤ 35,2m			10 - 50		4x6,8	4x5	
			RT 443 A1 2V			15 - 30		4x5	4x3,7	
			TCV 449 ARC H ≤ 35,2m			10 - 50		4x6,8	4x5	
			RT 443 A1 2V			15 - 30		4x5	4x3,7	
		RT 544 A1 2V			13,5 - 27		4x7	4x5,2		
		TCV 649 ARC H ≤ 43,4m			10 - 50		4x6,8	4x5		
Réseau - Netzstrom - Mains supply - Red - Rete elettrica							CEI 38 IEC 38	400V(+6%-10%) 50 Hz		
Puissance électrique nécessaire - Anschlusswert - Necessary electric power Potencia eléctrica necesaria - Potenza elettrica necessaria							PC : 50KVA RCS : 80KVA			
Groupe électrogène - Stromaggregat - Generator set - Grupo electrogeno - Gruppo elettrogeno							*			

*Nous consulter - Auf Anfrage - Consult us - Consultamos-Consultateci

Conforme aux directives CEE 84/534 et 87/405 sur le niveau acoustique - Gemäss EWG-Richtlinien 84/534 und 87/405 für den Schall- Leistungspegel
 In compliance with the EEC 84/534 and 87/405 Instructions on noise level - Conforme con las directivas CEE 84/534 y 87/405 sobre el nivel acustico
 Conforme alle direttive CEE 84/534 e 87/405 sul livello acustico

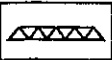

Lest de contre-flèche - Gegenauslegerballast - Counter-jib ballast
Lastre de contra flecha - Contrappeso

			(kg)
A	60m	14,5m	15 400 = (3x4200)+(4x700)
	55m	14,5m	13 300 = (3x4200)+(1x700)
	50m	12m	16 100 = (3x4200)+(5x700)
	45m	12m	14 700 = (3x4200)+(3x700)
	40m	12m	12 600 = (3x4200)
B	35m	12m	10 500 = (2x4200)+(3x700)
	30m	12m	9 100 = (2x4200)+(1x700)
	25m	12m	7 000 = (1x4200)+(4x700)

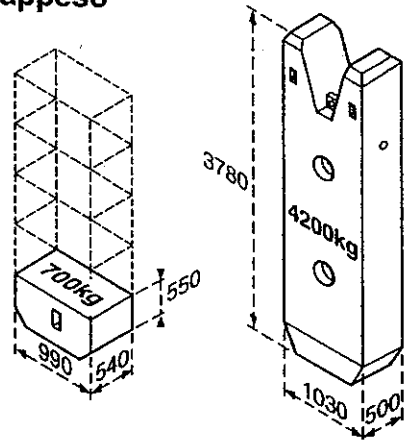

Lest de base - Grundballast - Base ballast - Lastre de base - Zavorra di base

H(m)	A	B	H(m)	A	B	H(m)	A	B	H(m)	A	B	H(m)	A	B
			56,9	102t	108t	54,4	85t	90t	68,4	120t	132t			
51,9	78t	84t	53,6	84t	90t	51	70t	75t	63,4	96t	108t			
48,5	60t	66t	50,2	72t	78t	47,7	55t	60t	58,4	72t	84t	48,1	70t	70t
45,2	48t	54t	45,2	48t	54t	42,7	40t	40t	53,4	60t	60t	44,7	50t	55t
40,2	42t	42t	40,2	42t	42t	37,7	40t	40t	48,4	36t	48t	39,7	40t	40t
35,2	42t	42t	35,2	42t	42t	32,7	40t	40t	43,4	24t	24t	34,7	40t	40t
30,2	42t	42t	30,2	42t	42t	27,7	40t	40t	38,4	12t	12t	29,7	40t	40t
25,2	42t	42t	25,2	42t	42t	22,7	40t	40t	33,4	12t	12t	24,7	40t	40t
20,2	42t	42t	20,2	42t	42t	17,7	40t	40t	28,4	12t	12t	19,7	40t	40t
15,2	42t	42t	15,2	42t	42t	12,7	40t	40t	23,4	12t	12t	14,7	40t	40t
S 40 A -●-			S 41 A -●-			ZD 46 A -●-			V 60 A -●-			ZD 46 A -●-		
						Ø 1,6m			Ø 2m					

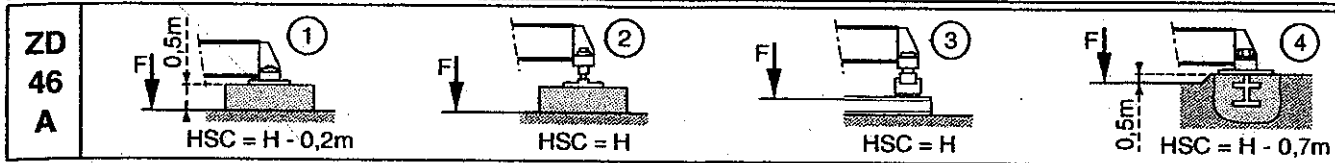



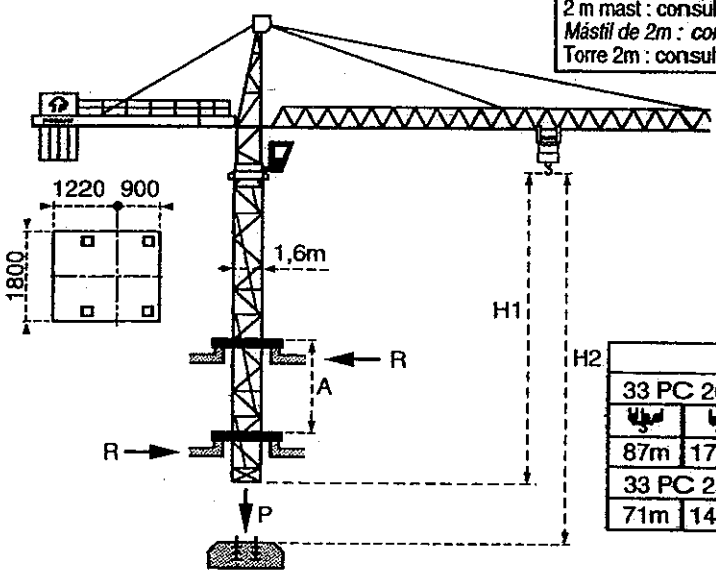

Télescopage sur dalles - Kletterkrane im Gebäude - Climbing crane
Telescopage gruas trepadoras - Gru in cavedio

Mât de 2m : nous consulter
 Mast von 2m : Auf Anfrage
 2 m mast : consult us
 Mástil de 2m : consultamos
 Torre 2m : consultateci

B 41



H2			
33 PC 20D	55 RCS 20D		
			
87m	174m	141m	283m
33 PC 25D	55 RCS 25D		
71m	142m	140m	280m

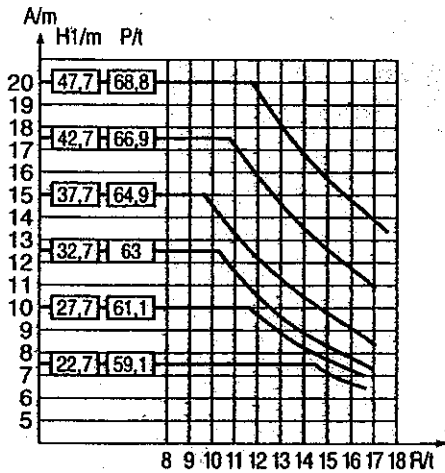

A Distance entre cadres	A Abstand zwischen den Rahmen	A Distance between collars	A Distancia entre marcos	A Distanza fra i telai
H1 Hauteur grue	H1 Kranhöhe	H1 Crane height	H1 Altura grúa	H1 Altezza gru
P Poids de la grue (en service)	P Krangewicht (in Betrieb)	P Crane weight (in service)	P Peso de la grúa (en servicio)	P Peso della gru (in servizio)
R Réaction horizontale	R Horizontalkräfte	R Horizontal reaction	R Reaccion horizontal	R Reazione orizzontale

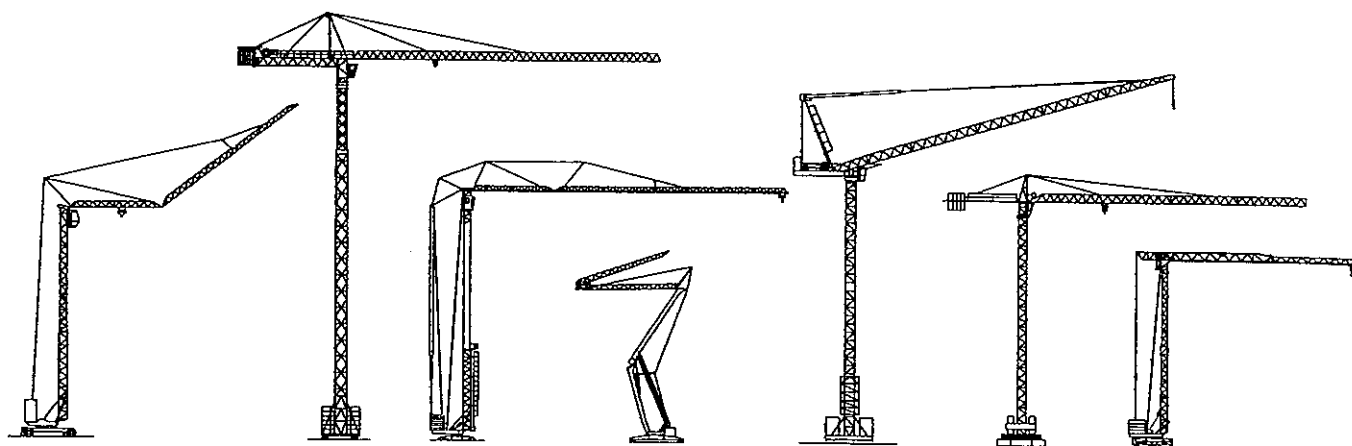

Document pour usage commercial uniquement - Benutzung dieser Unterlagen nur für Verkaufszwecke - Document for commercial use only -
 Documento para uso comercial unicamente - Documento per uso commerciale solamente

Copyright.Reproduction interdite © POTAIN 1992

POTAIN ↑[®]

GRUPE LEGRIS INDUSTRIES

18.Rue de Charbonnières, B.P. 173-F 69132 ECULLY Cedex
 Tél. 72.20.20.20 - Télex 375 213 - Fax 72.20.20.00

POTAIN GmbH	Deutschland	Tel : 06.105.704.0
POTAIN U.K.	Great Britain	Tel : 0895.44.52.61
Simma POTAIN	Italia	Tel : 02.97.96.71
POTAIN Portugal	Portugal	Tel : 02.968.08.89

MANTA EQUIPMENT (S) PTE. LTD.
 10 Tuas Drive 2 Singapore 638645
 Tel: 6227 7388 Fax: 6227 7288

TOPKIT MD 175

Réf. 1991.51 LDY 6

Modificaciones reservadas / Subject to modification / Änderungen vorbehalten / Modifications réservées / Printed in France / Modifiche riservate

Réalisation SODIPE